



Rules & Regulations Acknowledgement

In order to participate in the Ottawa Gatineau Golf Expo 2020, this Acknowledgement of the Rules and Regulations **must be fully completed and returned** by February 21st, 2020.

Return to:

NGCOA Canada
Eastern Ontario/Outaouais Chapter
Suite 810 – 515 Legget Drive
Kanata, Ontario
K2K 3G4
Fax: (613) 226-4148
Email: vkelly@ngcoa.ca

Exhibitor acknowledges and agrees to the Event Rules and Regulations as set forth below, which supplements the Agreement for Exhibit space.

Signature Date

Please complete (print) the following information:

Contact Name (as signed above) Title

Company

Address

Telephone incl. Area Code Email

On-Site Contact Telephone incl. Area Code

Booth Number



Rules & Regulations

Damage to Property

Use of nails, screws or any material that may mark and / or damage floors, walls, columns or ceilings is prohibited. Exhibitors wishing to lay any floor covering may not adhere same to the building floor. In such cases, it is suggested that building papers or other suitable protection be first laid down. If double sided tape is required the exhibitor must ensure that this tape is obtained from the Official Show Supplier as they use the industry standard tape. Due to the nature of the floor surface, additional care must be taken to not damage the floor by placing excess weight in any concentrated area. Exhibitor is liable for any damage caused to building floors, walls, columns or ceilings or to standard booth equipment. Any damage caused by an exhibiting company will be the responsibility of the exhibitor and all associated costs will be covered by the exhibitor.

Insurance

Current and in force Commercial General Liability Insurance coverage, with a minimum limit of \$1,000,000., is **mandatory** for all exhibitors that are participating in the Ottawa Gatineau Golf Expo 2016. Please note that the following parties should be named as "Additional Insured" on the document: Ottawa Gatineau Golf Expo **AND** Ernst & Young Centre. A copy of your insurance certificate is required by Show Management on, or before, February 21st, 2020. If a 3rd party supplier will be installing/dismantling the exhibit, show management will also require a copy of their current and in force Commercial General Liability Insurance coverage, with a minimum limit of \$1,000,000. Please fax a copy of this/these document/s to (613) 226-4148. Show Management reserves the right to refuse admission to any exhibitor who fails to comply with this regulation. In this event, no refund will be forthcoming from Show Management for exhibit costs.

Fire Prevention

No combustible or inflammable liquid or material may be used in any exhibit or display. All materials used for decorative purposes must be flameproof. All exhibit, display or demonstration installations must meet the requirements of all regulations and inspections enforced by the local Fire Department and the Ernst & Young Centre. Representatives of the fire safety department will inspect and may randomly test materials on the Show floor prior to and following the opening of the Show. It is important that any violations are immediately corrected.

Contests and Draws

Draws conducted by exhibitors in conjunction with their exhibit must be free of any obligation on the part of the winner. Prize winners must not be required to place an order before collecting the prize offered. The schedule of prizes and terms of the competitions must be clearly stated on the entry form. Exhibitors wishing to conduct a contest/draw at the Ottawa Gatineau Golf Expo 2017 must follow all rules under [Section 74.06 of the Competition Act](#) obtainable from Consumer and Corporate Affairs. Failure to comply with the rules of this Act constitutes a criminal offense. Fines could be as high as \$25,000, and imprisonment terms of up to 5 years. Contest/draw rules and regulations must state that such a contest/draw is conducted independently of the Show and that Show Management will NOT assume responsibility for any liability arising as a result of contest/draw being held at the Show. All such competitions must be approved by Show Management at least 2 weeks before the show and comply with all existing government regulations. All information gathered must be by means of a ballot which must include an option for attendees to "Opt Out" of all further communications from exhibitor. This ballot is subject to approval by show management, MUST be CASL compliant, and must be submitted for approval. A Contest/Draw/Ballot Approval Form will be available online and should be returned by February 21st, 2020.

Motorized Vehicle which forms part of an exhibit

Due to the nature of the Show floor surface, these are the only vehicles that will be allowed onto the show floor. All vehicles must be on the show floor by the time indicated by Show Management to the exhibitor in pre-show communications. Failure to comply with this regulation will result in the vehicle not being allowed onto the show floor.

OTTAWA-GATINEAU GOLFEXPO

- All internal combustion engine vehicles displayed in the facility must have less than 10 litres of fuel in their fuel tank. Vehicles that register a higher level will not be allowed to enter the facility. There will be no exceptions.
- Tanks cannot be refilled or emptied inside the facility or on facility property.
- Fuel tanks must be equipped with a locking gas cap, or taped closed.
- Battery cables must be disconnected and taped at the end.
- The facility floor under the vehicle must be protected with plastic sheeting and ¾" thick plywood of a predetermined dimension must be placed under each wheel of the vehicle to distribute the weight.
- During non-show hours, vehicles must be locked.
- A properly tagged set of keys to each vehicle must be left with Show Management prior to display.
- No repairs or alterations may be made to vehicles at any time from set-up to tear-down of the exhibit.
- Fire extinguishers, in appropriate numbers and classifications must be provided by the exhibitor, and all staff within the booth space must have sufficient knowledge of how to operate the extinguishers.

Alcoholic Beverages

The use or consumption of alcoholic beverages (spirits, wine and beer) by exhibitors, in their exhibit areas, is contrary to regulations set out by the Liquor Control Board of Ontario.

Signage

Exhibitors are permitted to display signs representing their products only in those areas for which they have contracted space. All signage must be professionally done. The top of all signage must be positioned a maximum of 8' from the floor. Any exceptions must be pre-approved, in writing, by Show Management. Signage may not be attached directly to the back drape. It may be hung by means of S-hooks from the top of the drape line piping.

In Booth Demonstrations

Regulation

Demonstration areas must be organized within the exhibitor's space so as not to interfere with any traffic aisle and sampling or demonstration tables must be placed a minimum of 2' (0.60 m) from the aisle line. Should spectators or samplers interfere with the normal traffic flow in the aisle or cause there to be an overflow into neighbouring exhibits, Show Management will request that the presentation be altered to remove the interference and / or the overflow. Show Management reserves the right to discontinue the sampling or demonstration if, in their sole discretion, the situation cannot be resolved satisfactorily.

Sound

Exhibitors must control their own booths to be sure that the noise levels from demonstrations or sound systems is kept to a minimum so as not to interfere with other exhibitors. Remember, the use of sound systems or equipment producing sound is an exception to the rule, not a right. Show Management reserves the right to determine at what point a noise or sound level constitutes interference with others and must be reduced or discontinued. Show Management reserves the right to discontinue the demonstration or the use of the sound system if, in their sole discretion, the situation cannot be resolved satisfactorily.

Safety Precautions

All product demonstrations involving any moving and potentially hazardous equipment or displays **must** have hazard barriers to prevent accidental injury to exhibitors, attendees and spectators. Demonstrations **must always** be supervised by exhibitor personnel who can stop the demonstration in the event of an emergency. All demonstrations involving potentially hazardous situations or by-products must have prior written approval from Show Management.

BOOTH DIMENSIONS

STANDARD BOOTH (10ft. wide x 10ft. deep x 8ft. high)

Height

Exhibit fixtures, components and identification signs will be permitted to a maximum of 8' (2.42 m).

Depth

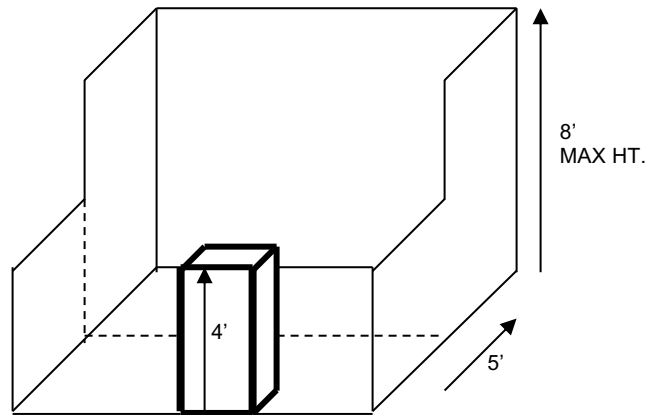

All display fixtures over 4' (1.22m) in height and placed within 10' (3.05 m) of an adjoining exhibit must be confined to that area of the exhibitor's space which is at least 5' (1.52 m) from the aisle line.

CANOPIES AND CEILINGS

Height

Canopies, false ceiling and umbrellas will be permitted to a height that corresponds to the height regulation for the appropriate exhibit configurations of which they are a part. For example, canopies will not exceed 8' (2.42 m) in height in a standard booth configuration. Furthermore, the canopy or false ceiling will not exceed 1' in depth and cannot be used for identification or display purposes.

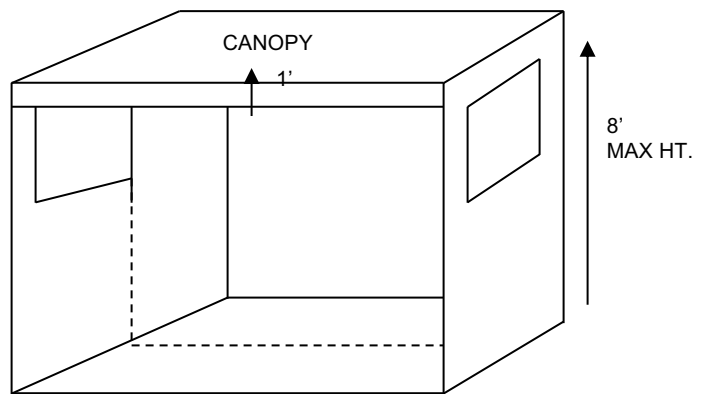

Note: This diagram is for indicating height only – full side walls are **not** permitted.

Canopy ceilings may extend out to the aisle line and up to the booth line on either side of an exhibitor's space providing that the support structure will not exceed 3" (0.075 m) in width when placed within 10' (3.04 m) of an adjoining exhibit and not confined to that area of the exhibitor's space which is at least 5' (1.52 m) from the aisle line.

Canopy side walls may not extend beyond 3 ft from the back wall of the exhibit space.

Canopies, false ceilings or umbrellas will not be used for identification or display purposes except as would normally be allowed for any exhibit component within the regulation set forth for the exhibit configuration.